

# PM Marine

## High Performance Speed Control

### Purpose

PM Marine is for medium voltage/high current motor operation from a standard radio. It is primarily designed for marine applications where no brake is required. With a maximum current rating of 90 Amps, it is possible to drive 2,500 Watts (2.5 kW) continuous.

### Features

- High Voltage (30 Vdc **maximum**, 18 cells max recommended)
- High variable current (120Amps for 10 secs, 90Amps continuous)
- Programmed for maximum power output and quick response.
- Very low on resistance (0.7m $\Omega$  or 0.0007 $\Omega$ ) for minimum loss.
- BEC, 1 Amp for single battery operation
- Small package, lightweight. (~3g without leads)
- Safe Start. Throttle must be passed below Neutral before PM Marine will activate.
- Micro controller controlled full digital operation for proper performance under adverse conditions (dust, moisture, electrical interference and vibration).
- Uses the very latest and best available surface mount components for the highest possible power output from the smallest package.
- Programmable for power & neutral positions, & ramp up if required.
- Accommodates all radios.
- No Radio Signal failsafe. Goes to Neutral after 1/8th sec. without radio signal, and flashes LED.
- LED which shows radio signal failure, full throttle, neutral, and assists in programming.
- Programmable soft power up. Ramping can be from 0 sec to approx. 0.6 sec. for full throttle range.
- Switch less programming.
- Brown Out detection.

### Mounting

PM Marine has mounting holes. Use mounting screws with plastic washers & standoffs. Some heat dissipation is required. **PM Marine is waterproof. Please do not encase, unless in a large container with other radio gear.** Ensure both sides of the circuit board are well ventilated, especially if very high currents are required.

### Connections

**Important :- It is extremely important that the motor has RF capacitors** to prevent radio interference and damage to PM Marine. If you have any doubt as to whether your motor has capacitors inbuilt, or as to their condition, solder a capacitor from each motor terminal to the motor casing & one between the terminals. Capacitors are supplied with PM Marine for this purpose. Tip:- The tidiest method is to lay out the three

capacitors in a triangle with the legs crossed. Twist the crossed legs together to form a star. Solder one star point to positive, one to negative and one to the casing.

PM Marine requires no external schottky diode, as it is included in the device.

Keep motor and battery wires as short as possible to reduce power loss and radio interference and keep radio wires away from power leads. Wire battery, motor and radio lead as per the following diagram. **A Receiver Battery is not required.**

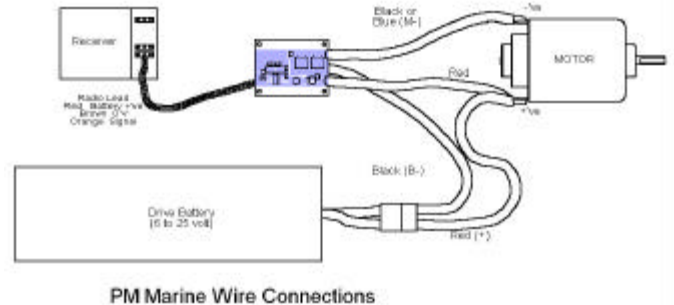

### Programming

**PM Marine has been programmed and tested, but will require reprogramming to suit your radio.**

PM Marine is programmable for Full Throttle, Neutral and Ramp Up.

To program PM Marine follow this procedure:-

1. Turn on the transmitter and apply full throttle.
2. Whilst still applying full throttle, turn on the receiver. (PM Marine may need to have been unplugged for 10 seconds or more to ensure a fresh start up)
3. PM Marine replies with two (2) flashes on the LED. (If 2 flashes aren't received, increase the throttle trim and repeat steps 1 & 2 again. If still no response, reverse the throttle output from the radio repeat steps 1 & 2 again. Most radios have reversing switches for this.
4. After receiving 2 flashes, return the throttle to Neutral. After 2 seconds PM Marine saves the Neutral setting and responds with 1 flash.
5. Move the throttle to where you want full throttle to occur. After 2 seconds PM Marine saves the Full Throttle setting and responds with 3 flashes.
6. Programming is finished and PM Marine is programmed without ramping.

So normal sequence is :-

F. Throttle \*\* \_ \_ Neutral \* \_ \_  
F. Throttle \*\*\* ready

where (\*) = LED flash and ( \_ ) = 1 second

### Ramping

- i. If after step 3 above the throttle is held at Full Throttle for a further 2 seconds, PM Marine will reply with two (2) more flashes on the LED.
- ii. Return the throttle to Neutral and re-apply within 1 second. The LED goes off and then back on. PM Marine counts 1 step of Ramp. You can skip this step or repeat it up to 8 counts. Each count programs PM Marine with approx. 0.07 second ramp (it will take PM Marine 0.07 sec to

achieve full throttle from neutral if full throttle is applied suddenly) up to a max. ramp time of ~0.6 seconds.

- iii. Return the throttle to Neutral. PM Marine will wait 1 second and flash 3 times. Ramping is now programmed.

Sequence is :-

**F. Throttle \*\* \_ \_ maintain F. Throttle \*\*  
Pulse throttle (0 to 8 times for Ramping)  
Neutral \_ \*\*\* ready**

where (\*) = LED flash and ( \_ ) = 1 second

Note :- Both the previous sequences can be repeated as often as you wish, each one being completely independent of the other, so that Ramping can be readily reprogrammed without effecting the throttle positions.

Note 3 :- If Ramping is programmed to 8 steps, PM Marine will automatically proceed to the end of programming without waiting for the 1 second of Neutral.

**Warning** – PM Marine may not be isolated. Prevent shorts with motor or battery terminals.

**Warranty** - PM Marine is warranted for life against faulty parts or workmanship. Abuse, reverse connections & exceeding maximum ratings are not covered.

## Specs

Dimensions	28 x 33 x 8.5 mm with tabs.
Weight	~3g without leads
Rating	6-30Vdc, 120 Amp (10 seconds)
Max. current	644 Amp continuous, 2480 peak (mosfet spec.)
Tested continuous current	90 Amps
On Resistance	0.7 mOhms (0.0007 Ohms)
Suitable Motor	Any
BEC radio connection	5Vdc, 1Amp cont., 2 Amp peak
PWM frequency	4 kHz fixed
Throttle	Fully variable from 12% to full
Ramping	Adjustable 0 to 0.6 seconds (8 steps)
Maximum mosfet temp.	60°C

**Contact** Ian Armstrong  
Email [iarmstrong@austarnet.com.au](mailto:iarmstrong@austarnet.com.au)  
Web <http://home.austarnet.com.au/iarmstrong>  
Mob. 0403 403 145

## Disclaimer

*Although great care was taken in designing, programming and assembly of this speed controller, the end user will take all responsibility for any damage or injury caused by any device containing this controller. Due to the nature of radio control, no guarantees can be given as to the safe use of this product.*